

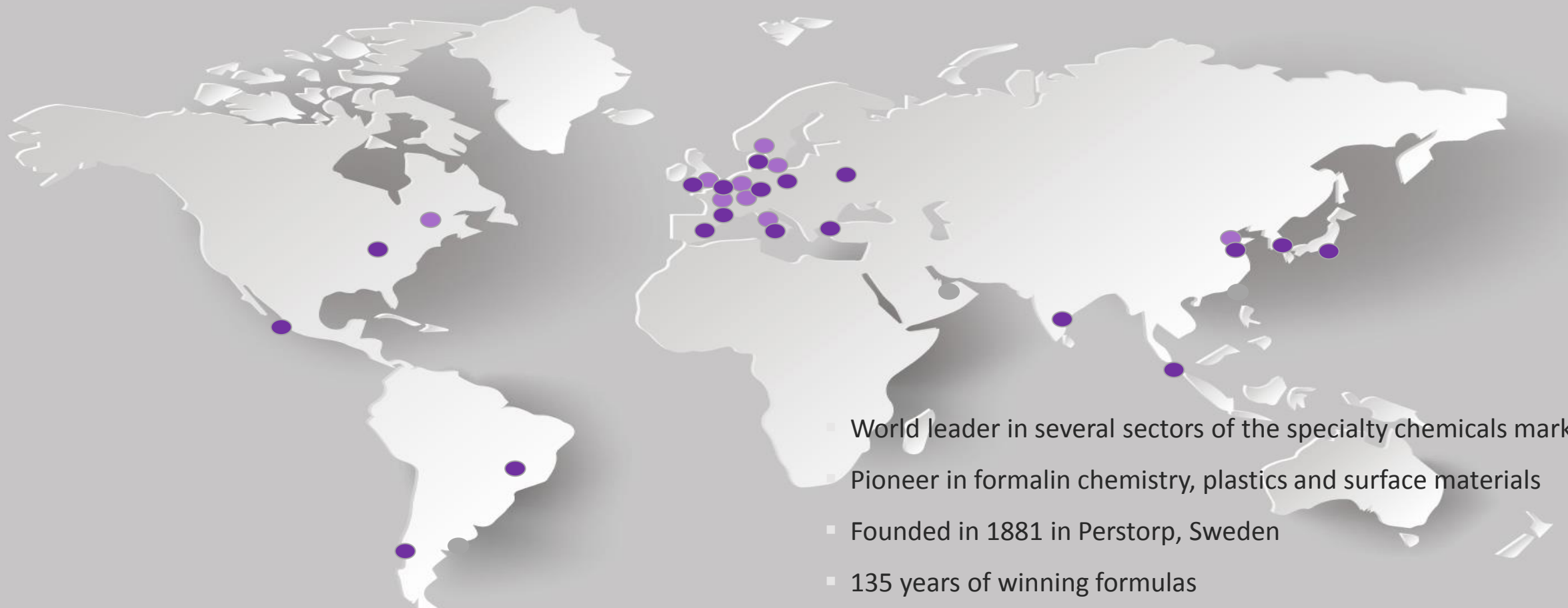

# Functionality 4.0

Capa™ 4101 in high performance two component polyurethane coatings.

# Everywhere you need us



- World leader in several sectors of the specialty chemicals market
- Pioneer in formalin chemistry, plastics and surface materials
- Founded in 1881 in Perstorp, Sweden
- 135 years of winning formulas
- 1,500 employees in 22 countries

# Capa™ Polyols

- A range of aliphatic polyester polyols produced in Warrington, UK.
- Products for a whole range of polyurethane applications.
- Main characteristics:
  - Low viscosity
  - Solvent free
  - Excellent hydrolysis resistance
  - Excellent mechanical properties

Made for tough conditions



# Capa™ 4101

- Polycaprolactone based polyester polyol
- OH number 218 mg/KOH (6.8% OHV)
- Tetrafunctional with equivalent weight of 250

- > Lowers VOC.
- > Improves impact resistance.
- > Improves abrasion resistance.
- > Improves chemical resistance.

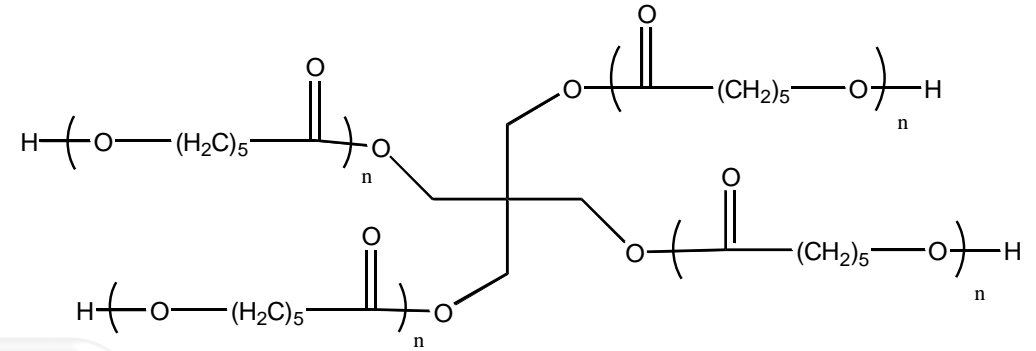

# Formulation approach

- Start with a high performance acrylic system.
- Solvent added to reach spray viscosity
- Increasing % weight of Capa™ 4101

Item	Supplier	Grind Part
		Parts
SM2810/75	Allnex	35.68
Butyl Acetate		30.5
TiPure R960	Chemours	18.38
Tinuvin 1130	BASF	0.32
Tinuvin 292	BASF	0.32
DynoAdd F1	Dynoadd	0.54
DBTN Cat. 10% in BA		0.54
Incozol 2	Incorez	2.16
Totals:		88.44



Let down		Reference 0%	1.54% w/w Capa™ 4101	3.85% w/w Capa™ 4101	7.70% w/w Capa™ 4101	11.6% w/w Capa™ 4101
	Supplier	Parts	Parts	Parts	Parts	Parts
Additional 2810/75	Allnex	11.56	10.02	7.71	3.86	0
Capa™ 4101	Perstorp	0	1.54	3.85	7.7	11.56
Total Parts Part A		100	100	100	100	100
HDT LV2	Vencorex	21.8	22.37	23.26	24.72	26.19
NCO/OH		1.05	1.05	1.05	1.05	
Total Weight		121.8	122.37	123.26	124.72	126.19

\*Spray viscosity at 100mPa.s

# Pre-applied Lowers VOC

Potlife measured as viscosity

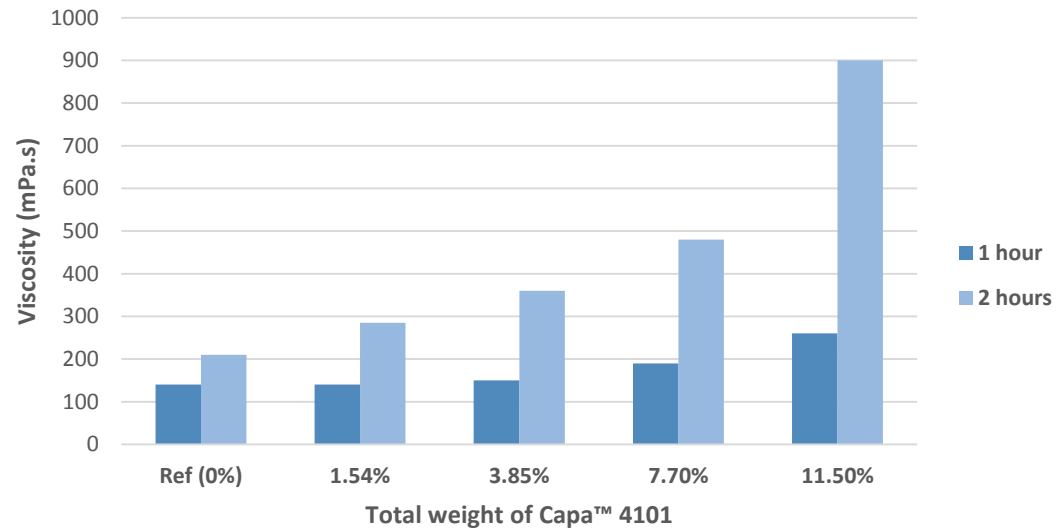

Total solids content (TSC) and volatile organic content (VOC)

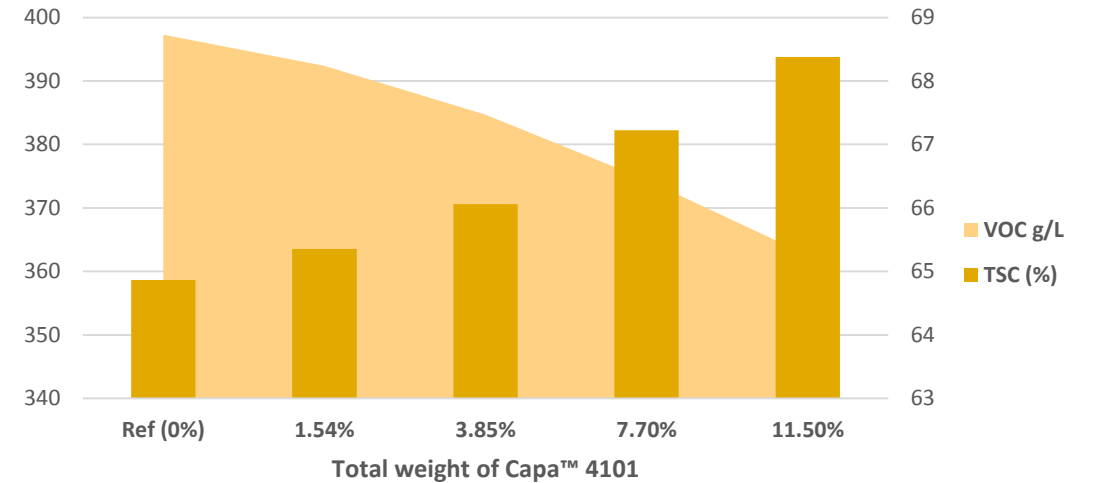

- Minimal impact on pot life in the lower percentages.
- Increased solids content/lowered VOC at spray viscosity.

# Initial Appearance

Gloss on dry films (1.5 - 3mils)

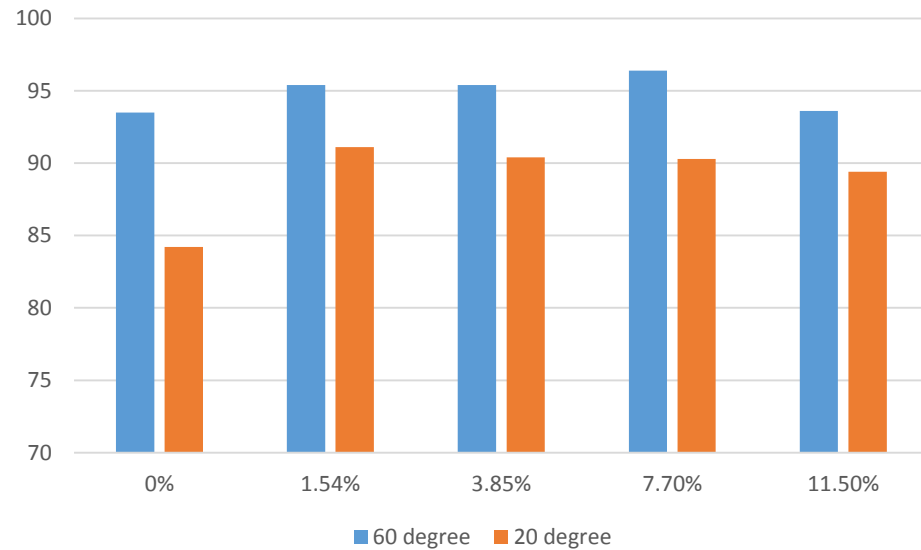

Konig Hardness

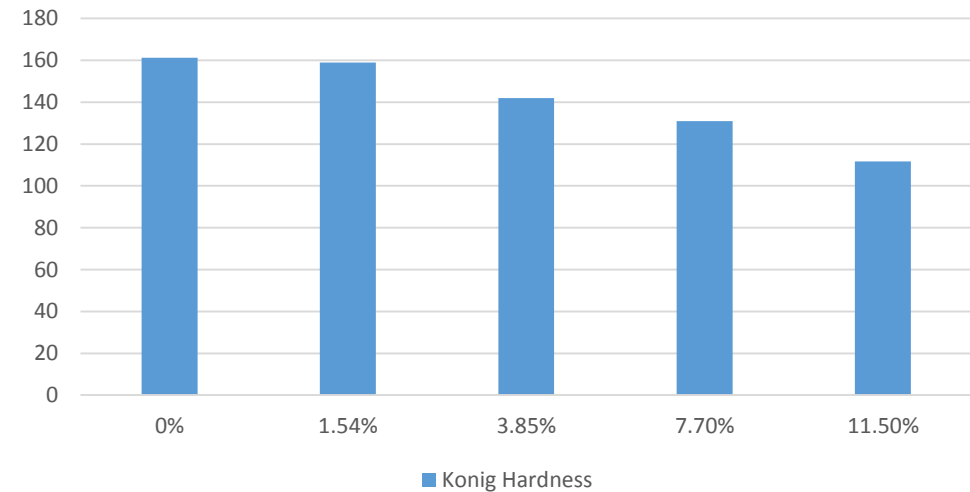

- Improved gloss.
- Increase in pencil hardness.
- Reduction in Konig Hardness.

Pencil Hardness #52 rod on un-primed Q-Panels					
(173 gram standard weight applied to stylus with pencil. Tested in duplicate)					
Panel A	HB	HB	F	2H	3H
Panel B	HB	HB	F	2H	3H

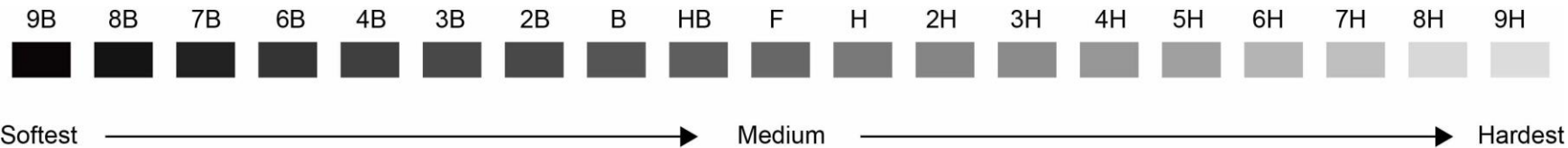

# Mechanical Properties

## Improved Impact Resistance

- Significant increase in impact resistance.
- Improved impact resistance with and without primer.

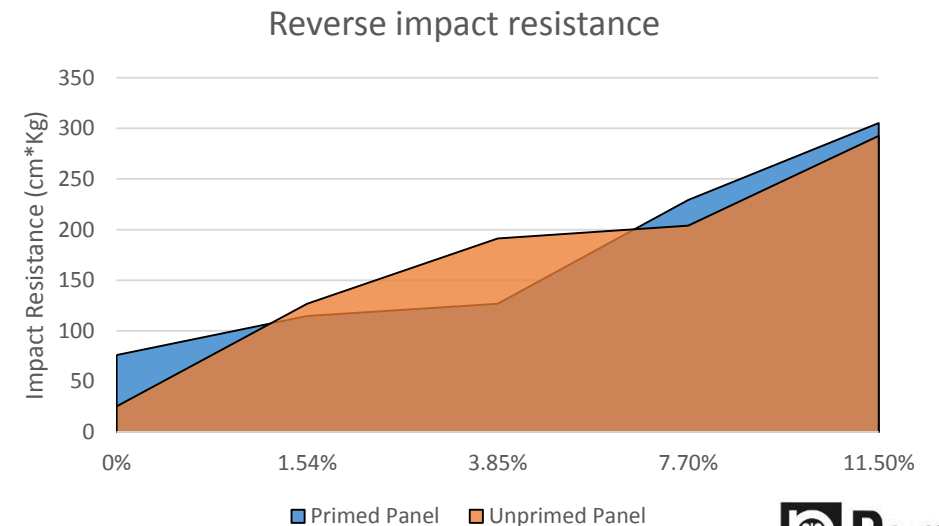
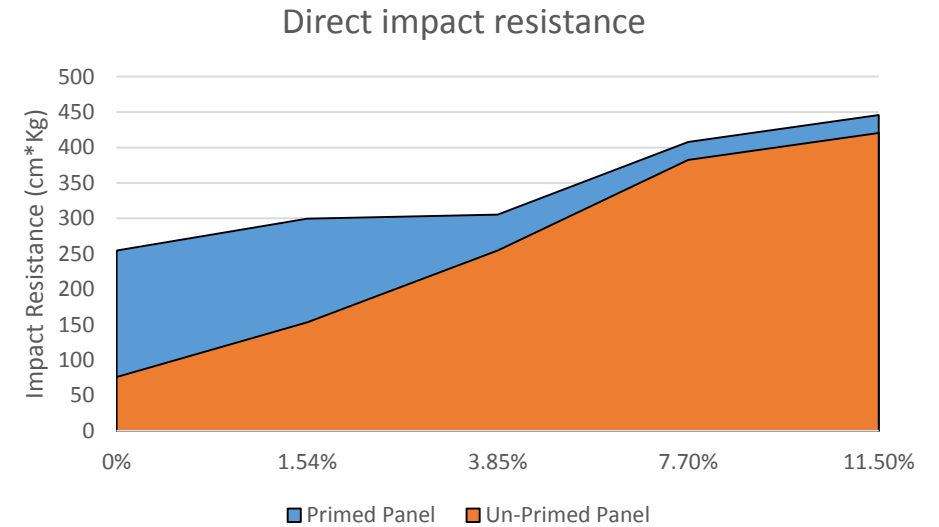



# Mechanical Properties Improves Impact Resistance

- Impact resistance tested at -10°C
- Primed vs unprimed trend reversed
- Similar linear improvement of impact resistance

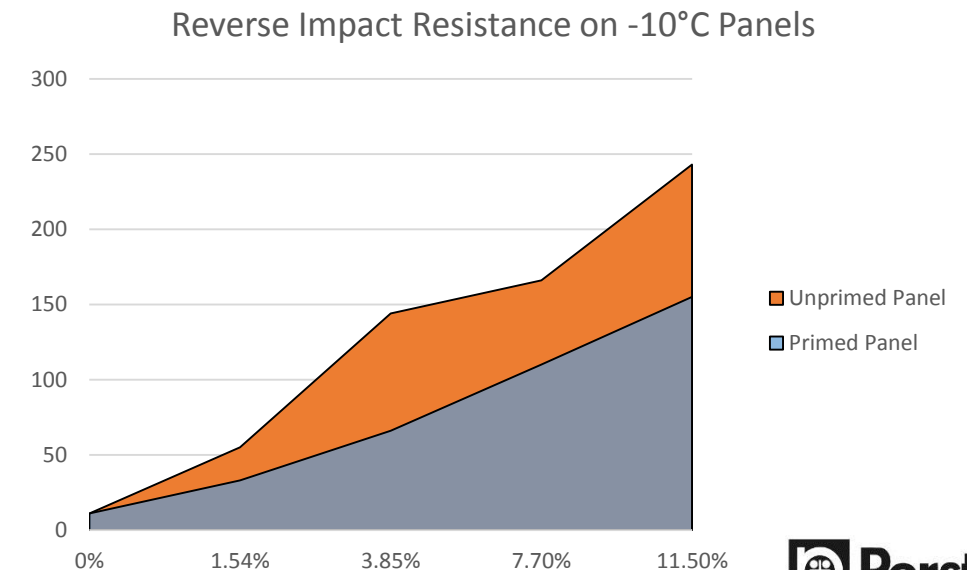
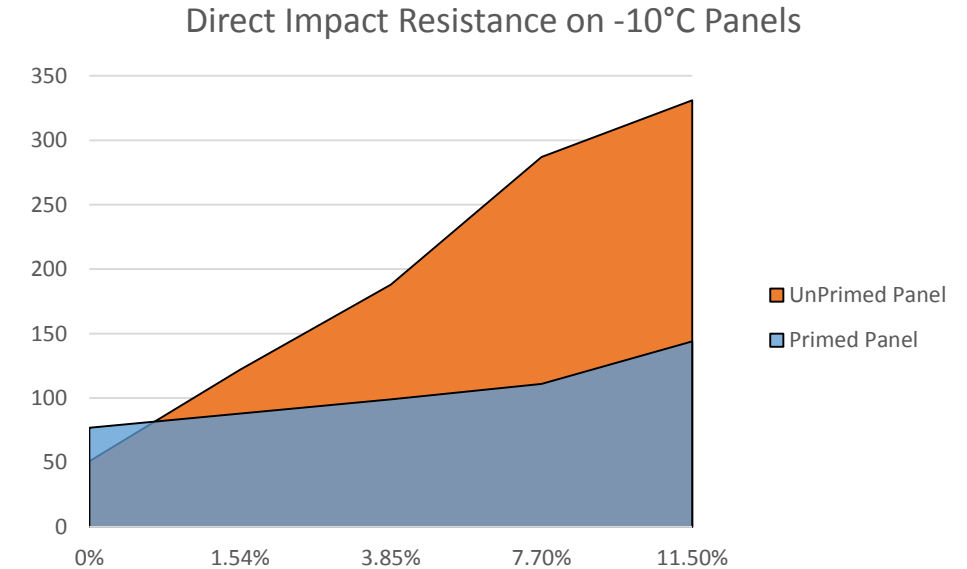

# Mechanical Properties

## Improves Abrasion Resistance

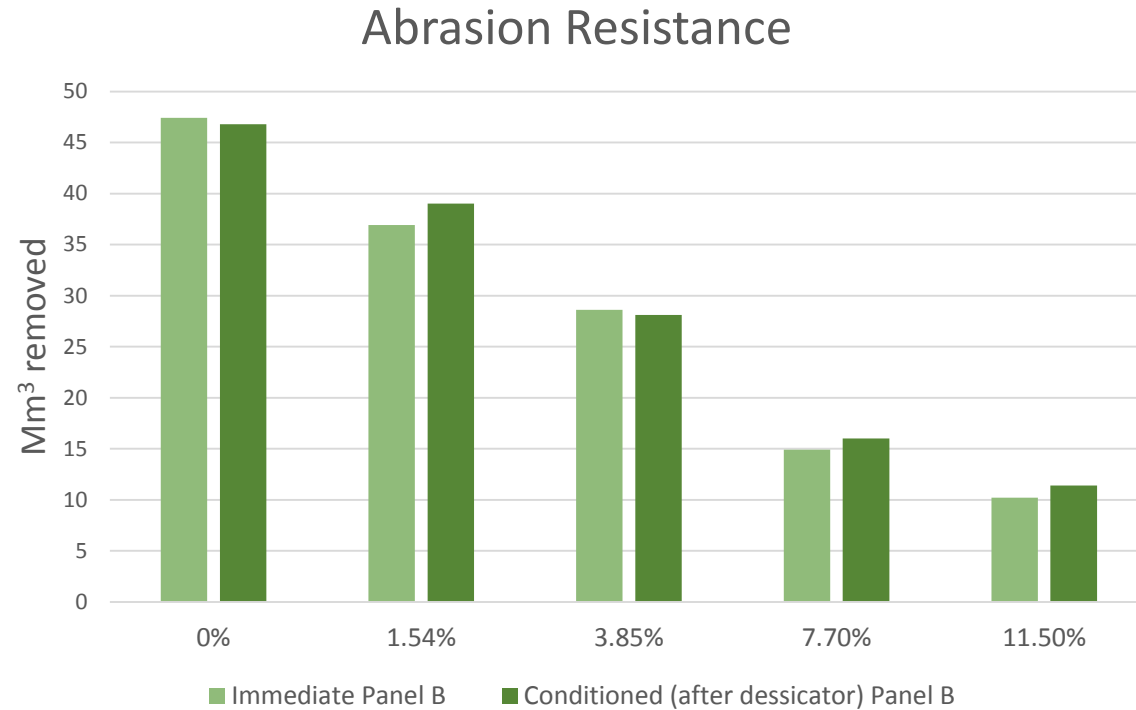

- CS17 wheels/ 1000 gram weight/ 1000 cycles
- Panels primed and coated with #52 rod topcoat deposition. –
- Sample panels conditioned 24 hours in dessicator prior to abrasion testing.
- MG loss results recorded immediately after test completion and after 24 hours re-conditioning in dessicator. -
- Each system tested in duplicate. Results reported in mg loss/1000 cycles

# Chemical Resistance

- Incremental improvement in chemical resistance
- MEK resistance after 300 double rubs
- Acrylic initial performance is good

MEK Double Rubs on Primed Q-Panels					
	0	1.54%	3.85%	7.70%	11.50%
Primed Panel 300 double rubs	Mars with degloss	Slight Mar with slight degloss	No Effect	No Effect	No Effect

12 Hour Exposure- Observations immediately after removal of chemicals					
	0	1.54%	3.85%	7.70%	11.50%
Glacial Acetic Acid	Destroyed	Destroyed	Destroyed	Destroyed	Destroyed
Skydrol LD-4	Slight Mark	Slight Mark	Slight Mark	Slight Mark	Slight Mark
Purell Hand Cleaner	No Affect	No Affect	No Affect	No Affect	No Affect
60:40 Gasoline/Toluene mix	Slight Mark	Slight Mark	Slight Mark	Slight Mark	Slight Mark
De-Icer (Methanol/Ethylene Glycol Mix)	Slight Mark	No Affect	No Affect	No Affect	No Affect
Synthetic Brake Fluid	Degloss	Slight Degloss	Slight Degloss	Slight Degloss	Slight Degloss
Automatic Transmission Fluid	No Affect	No Affect	No Affect	No Affect	No Affect
Synthetic Gear Oil (Grade 460)	Slight Degloss	Slight Mark	No Affect	Slight Mark	Slight Mark

# Conclusions Capa™ 4101

- Branched aliphatic polyester polyol.
- Reactive diluent and resin modifier.
- Functionality 4.0
  - › Reduces solvent demand
  - › Improves impact resistance
  - › Improves abrasion resistance
  - › Improves chemical resistance
- Begin to optimise coating properties with as little as 2-4% addition rate.
- Many thanks to Habbco Industries LLC, MA



Welcome to hall 7A booth 603 to discuss further